

Marine Inquiry 11-201, Passenger vessel *Volendam*, lifeboat fatality,
Port of Lyttelton, New Zealand, 8 January 2011

The Transport Accident Investigation Commission is an independent Crown entity established to determine the circumstances and causes of accidents and incidents with a view to avoiding similar occurrences in the future. Accordingly it is inappropriate that reports should be used to assign fault or blame or determine liability, since neither the investigation nor the reporting process has been undertaken for that purpose.

The Commission may make recommendations to improve transport safety. The cost of implementing any recommendation must always be balanced against its benefits. Such analysis is a matter for the regulator and the industry.

These reports may be reprinted in whole or in part without charge, providing acknowledgement is made to the Transport Accident Investigation Commission.



Final Report

Marine Inquiry 11-201, Passenger vessel *Volendam*, lifeboat
fatality,
Port of Lyttelton, New Zealand, 8 January 2011

Approved for publication: October 2011

Transport Accident Investigation Commission

About the Transport Accident Investigation Commission and this report

The Transport Accident Investigation Commission (Commission) is an independent Crown entity responsible for inquiring into maritime, aviation and rail accidents and incidents for New Zealand, and co-ordinating and co-operating with other accident investigation organisations overseas. The principal purpose of its inquiries is to determine the circumstances and causes of the occurrence with a view to avoiding similar occurrences in the future. Its purpose is not to ascribe blame to any person or agency or to pursue (or to assist an agency to pursue) criminal, civil or regulatory action against a person or agency. The Commission carries out its purpose by informing members of the transport sector, both domestically and internationally, of the lessons that can be learnt from transport accidents and incidents.

Commissioners

Chief Commissioner	John Marshall, QC
Deputy Chief Commissioner	Helen Cull, QC
Commissioner	Captain Bryan Wyness
Assessor	Keith Ingram

Key Commission personnel

Chief Executive	Lois Hutchinson
Chief Investigator of Accidents	Captain Tim Burfoot
Investigator in Charge	Captain Iain Hill
General Counsel	Rama Rewi

Email: inquiries@taic.org.nz

Web: www.taic.org.nz

Telephone: + 64 4 473 3112 (24 hrs) or 0800 188 926

Fax: + 64 4 499 1510

Address: Level 16, AXA Centre, 80 The Terrace, PO Box 10 323, Wellington 6143, New Zealand

Important notes

Nature of the final report

This final report has not been prepared for the purpose of supporting any criminal, civil or regulatory action against any person or agency. The Transport Accident Investigation Commission Act 1990 makes this final report inadmissible as evidence in any proceedings with the exception of a Coroner's inquest.

Ownership of report

This report remains the intellectual property of the Transport Accident Investigation Commission.

This report may be reprinted in whole or in part without charge, provided that acknowledgement is made to the Transport Accident Investigation Commission.

Citations and referencing

Information derived from interviews during the Commission's inquiry into the occurrence is not cited in this final report. Documents that would normally be accessible to industry participants only and not discoverable under the Official Information Act 1980 have been referenced as footnotes only. Other documents referred to during the Commission's inquiry that are publicly available are cited.

Photographs, diagrams, pictures

Unless otherwise specified, photographs, diagrams and pictures included in this final report are provided by, and owned by, the Commission.



Photograph courtesy of Holland America Line

M.V. Volendam



Location of accident

Contents

- 1. Executive summary1
 - Summary.....1
 - Key lessons.....1
- 2. Conduct of the inquiry.....2
- 3. Factual information.....3
 - 3.1. Narrative3
 - 3.2. Vessel information.....4
 - 3.3. Lifeboat and its launching arrangement.....4
 - Davits.....4
 - Lifeboats4
 - Wire falls6
 - 3.4. Inspection and testing.....8
 - Davit 8
 - Wire fall.....8
 - 3.5. Personnel information..... 11
 - 3.6. On board working practices 12
 - 3.7. Maintenance regime 12
 - 3.8. Survival aspects..... 13
- 4. Analysis 15
 - 4.1. Introduction..... 15
 - 4.2. Why the lifeboat fall failed 15
 - 4.3. Why the crew members fell into the sea..... 16
 - 4.4. The importance of wearing lifejackets when working over water..... 17
 - 4.5. Violation of good company procedures..... 18
 - 4.6. Design and maintenance of the lifeboat launching davit 20
- 5. Findings..... 22
- 6. Safety actions 23
 - Safety actions addressing safety issues identified during an inquiry..... 23
- 7. Recommendations 25
 - General 25
 - Recommendations..... 25
 - Recommendation 1..... 25
 - Recommendation 2..... 25
 - Recommendation 3..... 25
- 8. Key lessons..... 27
- 9. Citations..... 28
- Appendix 1 Navalimpianti Technimpianti Service Bulletin 29
- Appendix 2 Navalimpianti Technimpianti 31
- Appendix 3 Job hazard analysis sheet 0001..... 32
- Appendix 4 Job hazard analysis sheet 0009 33

Appendix 5 Working aloft permit	34
Appendix 6 Toolbox discussion for	35

Figures

- Figure 1 Number 7 lifeboat in vertical position after failure of wire fall 3
- Figure 2 Diagram of the telescopic davit system as fitted to the *Volendam* 5
- Figure 3 Wire fall reeving diagram..... 6
- Figure 4 Diagram of davit construction..... 7
- Figure 5 Number 7 forward davit showing moveable trolley beam and wire break point 7
- Figure 6 Head of number 7 forward fixed davit arm 9
- Figure 7 Vertical bracket from number 5 trolley beam 9
- Figure 8 Number 5 davit beam (fixed part) showing deflection 10
- Figure 9 Photograph of the failure point of number 7 lifeboat forward wire fall 10
- Figure 10 Enlarged photograph of failure point of number 7 lifeboat wire fall..... 11
- Figure 11 Starboard side of the *Volendam* looking aft from the navigating bridge showing position of davit ends and stowage positions..... 15
- Figure 12 Diagrammatic representation of aft fall hook failure 17

Abbreviations

°C	degree(s) Celcius
HAL	Holland America Line
ISM code	International management code for the safe operation of ships and for pollution prevention
JHA	job hazard analysis
kW	kilowatt(s)
LMC	Lloyds machinery certificate
m	metre(s)
mm	millimetre(s)
PPE	personal protective equipment
SOLAS	International Convention for the Safety of Life at Sea 1974
t	tonne(s)
UMS	unmanned machinery space certification
UTC	co-ordinated universal time

Glossary

✱	new vessels constructed under a classifications society's special survey
100 A1	ship considered to be suitable for sea-going service, accepted into class as complying with the society's rules and regulations and carrying on board an anchor or mooring equipment complying with the society's rules.
davit	a fitting that can project over a vessel's side for attaching tackle for hoisting or lowering a boat
elastic deformation	deformation to an object that is reversible. Once the forces are no longer applied, the object returns to its original shape
fall wire	wire rope by which a lifeboat is hoisted or lowered.
kilo	the prefix kilo- denotes a multiple of 1000 in the International System of units (SI Units)
Newton	the absolute unit of force in the International System of units (SI Units). It is defined as that force necessary to provide a mass of one kilogram with an acceleration of one metre (m) per second per second.
plastic deformation	deformation to an object that is irreversible. However, an object in the plastic deformation range will first have undergone elastic deformation, which is reversible, so the object will return part way to its original shape
traveller wires	wires attached to a telescopic davit arm, enabling a section of the arm to extend farther out than the end of the moveable trolley

Data summary

Vessel particulars

Name:	<i>Volendam</i>
Type:	passenger vessel
Class:	SOLAS
Limits:	unlimited
Classification:	Lloyds Register LR ✕ 100 A1, Passenger Ship, Ice Class 1D ✕ LMC, UMS
Length:	237.90 metres (m)
Breadth:	32.45 m
Gross tonnage:	61 214
Built:	Fincantieri Shipyard, Maghera, Italy
Propulsion:	Five 8640 kilowatt (kW) diesel generators providing electrical power for two 13 000 kW electric motors driving two, 4-bladed variable-pitch propellers
Service speed:	22.5 knots (kts)
Owner:	HAL Antillen N.V.
Operator:	HAL Westours Incorporated.
Port of registry:	Rotterdam
Minimum crew:	57
Minimum working crew:	620

Date and time	Saturday 8 January 2011, at about 1357 ¹
Location	Lyttelton, South Island, New Zealand
Injuries	one fatality one minor
Damage	one lifeboat constructively lost one tender/lifeboat repairable damage to hull

¹ Times in this report are in New Zealand Daylight Time (UTC + 13 hours) and are expressed in the 24-hour mode.

1. Executive summary

Summary

- 1.1. On the afternoon of 8 January 2011, the passenger vessel *Volendam* was alongside in Lyttelton. Some of the crew were carrying out routine maintenance on one of the starboard lifeboats when at about 1400 the forward lifeboat fall wire parted and 2 crew members fell into the water; the lifeboat remained suspended by the aft lifeboat fall wire.
- 1.2. The alarm was raised and a rescue boat and crew were launched shortly afterwards. One of the crew members who had fallen into the water was recovered by the rescue boat. However, the other crew member could not be found despite a search being carried out by the vessel's rescue boat, the port authority, the coastguard and emergency services.
- 1.3. The body was eventually found and retrieved from the sea bed some 4 hours later by port authority divers. The lifeboat was irreparably damaged and the tender launch aft of the lifeboat was also damaged, requiring repairs to the hull before the *Volendam* could sail.
- 1.4. Both crew members who fell into the water were wearing safety harnesses that were attached to a line strung between the lifeboat's lifting hooks. When the fall wire failed this line also failed. Neither of the crew members was wearing any form of buoyancy aid or lifejacket.
- 1.5. A subsequent investigation into the failure mechanism of the forward fall wire showed that the wire in the failure zone was heavily corroded which caused a loss of structural strength in the immediate vicinity of the failure. The final failure was due to a tensile fracture of the remaining cross section of the wire.
- 1.6. Because of the design of the lifeboat davits, the wire in the vicinity of the failure, was difficult to access to apply a protective coating of grease to the wire, and it was difficult to ensure that the coating was applied around the whole circumference of the wire in this area.
- 1.7. On inspection of the remaining davit systems on board the vessel, 10 fall wires were found to be sufficiently corroded in an area at or near the fixed point termination to require remedial action.
- 1.8. Three urgent safety recommendations were made to the manufacturer of the davit systems, to:
 - alert all owners of vessels fitted with the SPTDL-150P model of davit fitted to the *Volendam* to the circumstances of this accident and issue instructions on what immediate inspections should be carried out
 - make a technical assessment of other lifeboat davit models it had produced to identify similar safety issues existing with these models, and if so alert owners of these models
 - review the design of the davit system SPTDL-150P with a view to remedying the tendency in this case for the fixed arm davit to flex inwards under load and contact moving parts of the structure.

Key lessons

- A wire rope is only as good as its weakest part. Unless an inspection covers the entire length of the wire, a thorough inspection has not been made.
- Wire ropes in a marine environment require frequent and thorough lubrication to prevent corrosion; otherwise other measures will need to be taken to prevent premature failure of the wire ropes.
- When selecting a securing point for a safety harness, consideration should be given to its vulnerability in the event of other catastrophic failures.
- A personal buoyancy device should always be worn when working outside a ship's rail.
- Robust job hazard analysis (JHA) can prevent injuries and save lives, but only if the procedures that result are then followed by the crew.

2. Conduct of the inquiry

- 2.1. On 8 January 2011 at about 1524, the Transport Accident Investigation Commission (Commission) learnt from Maritime New Zealand that an accident had occurred earlier that afternoon on board the passenger ship *Volendam* while berthed at Lyttelton.
- 2.2. The accident fell into the category of a “very serious accident” as defined in the International Maritime Organization’s casualty investigation code, which requires states to conduct investigations under the code. The Commission opened an inquiry into the occurrence.
- 2.3. During the night of 8 January 2011 the Commission was contacted by the Dutch Safety Board and an agreement was reached that the Commission would investigate the accident in its own right and also on behalf of the Dutch Safety Board. An agreement was made that New Zealand would also be the reporting State for the accident to the International Maritime Organization.
- 2.4. On 9 January 2011, 2 investigators from the Commission boarded the vessel when it arrived in Wellington and met with the senior officers on board. After a briefing with the master and senior officers, the scene of the accident was inspected and members of the crew involved in the accident and subsequent search and rescue were interviewed. Access to the failed wire was limited as the vessel was berthed port side to the quay.
- 2.5. The *Volendam* sailed from Wellington the same evening and during its subsequent port stays in Napier, Tauranga and Auckland the failed wire fall was removed and retained by the Commission. All the remaining wire falls, their attachment arrangements and the davit heads were inspected by a Lloyds Register Asia surveyor. The Commission received a copy of the surveyor’s report.
- 2.6. The Commission engaged the New Zealand Defence Technology Agency to establish the nature of the wire failure.
- 2.7. On 23 February 2011, the Commission approved an interim factual report for publication. The report included urgent safety recommendations issued to the manufacturer of the davit system to address safety issues identified.
- 2.8. On 26 August 2011 the Commission approved a draft final report to be circulated to interested persons for comment.
- 2.9. The draft final report was sent to 14 interested persons with a request that submissions be forwarded to the Commission no later than 30 September 2011. A written submission was received from Holland America Line on its own behalf and that of its employees. One verbal submission was received from Maritime New Zealand indicating that it would not be making a written submission on the report.
- 2.10. On 26 October 2011 the Commission approved the publication of the final report

3. Factual information

3.1. Narrative

- 3.1.1. On Saturday 8 January 2011, the Dutch-registered passenger vessel *Volendam* berthed in the port of Lyttelton.
- 3.1.2. At about 0800, 4 crew members were tasked with the routine maintenance job of greasing the lifeboat fall and traveller wires on number 7 lifeboat on the starboard side. A “working aloft” permit was issued for the task, because it required the crew members to be working at height outboard of the vessel’s rail. A “Toolbox Discussion” form was signed by all 4 crew members before starting the task. The crew members started this job at about 0830.
- 3.1.3. Two of the crew members were standing on the access platform, one greasing the wire falls on the winch drum and one operating the controls to boom the telescopic davit in and out and lower and raise the lifeboat as required to facilitate the greasing of the wires.
- 3.1.4. Two crew members were standing on the top of the lifeboat greasing the wire falls and davit traveller wires. They were attached by safety harnesses, clipped to a safety line that had been strung tight between the forward and aft lifeboat lifting hook arrangements, but neither was wearing a personal flotation device.
- 3.1.5. At about 1355, the job was nearing completion. The 2 crew members on top of the lifeboat requested the crew member at the controls to lower the lifeboat a short distance from the lifeboat’s extreme height against the davit trolley arm. At this time the davit arm was fully extended.
- 3.1.6. As the winch operator was lowering the lifeboat the forward lifeboat wire fall parted and the lifeboat fell bow down, suspended by the aft lifeboat fall (see Figure 1).



Figure 1
Number 7 lifeboat in vertical position after failure of wire fall

- 3.1.7. The aft lifting hook bent backwards under the strain, tearing a path through the fibreglass hull as it did so. As a consequence the safety line rigged between the lifting hooks parted. Because it was this line to which the crew members had attached their safety harnesses, the 2 crew members on the lifeboat fell about 16 m into the water.

3.1.8. The crew on board the *Volendam* raised the alarm and one of the vessel's rescue boats was launched shortly afterwards. One crew member managed to grab a floating bucket of grease and use this to help stay afloat. He was rescued. The crew member who had been at the front of the lifeboat was seen briefly above water in what appeared to others to be a dazed state, but he soon disappeared. Searches by the vessel's crew and emergency services failed to find him. Later that evening divers recovered his body from the seabed near where he had fallen into the sea.

3.2. Vessel information

3.2.1. The *Volendam* was built by Fincantieri Shipyard in Maghera, Italy in 1998. The vessel was owned by HAL Antillen N.V. of Curacao Dutch Antilles, and operated by HAL Westours Incorporated of Seattle, Washington, United States of America. The vessel was registered in Rotterdam, Netherlands and had valid certificates issued by the Dutch Government and by the Lloyds Register classification society.

3.2.2. The *Volendam* was a steel-hulled passenger vessel with an overall length of 237.90 m and a breadth of 34.45 m. The vessel had an international gross tonnage of 61 214. It was powered by five 8640 kW diesel electric generators powering two 13 000 kW electric motors driving two 4-bladed variable-pitch propellers, giving a service speed of up to 22.5 knots.

3.2.3. The *Volendam* was certified to carry 620 crew and 1805 passengers. The vessel was fitted with 14 motor lifeboats accommodating 1920 persons, 16 davit-launched life rafts accommodating 560 persons and 18 life rafts accommodating 630 persons.

3.3. Lifeboat and its launching arrangement

Davits

3.3.1. The davits on board the *Volendam* were designed, manufactured and supplied by Navalimpianti Tecnimpianti Group to the Fincantieri Shipyard. The davits for the lifeboats were of SPTDL-150P design and differed from the davits for the cruise tenders and the rescue boats.

3.3.2. The SPTDL-150P davits were hydraulic telescopic davits that used hydraulic rams to move the telescopic trolley arms outboard from the stowed position and recover them when necessary. The system was designed to ensure that both davit trolley arms always moved together². Power was provided by 2 centralised hydraulic power packs on the port and starboard sides of the vessel.

3.3.3. The telescopic trolley arms of the davits were designed to support a safe working load of 86 kilonewtons. The telescopic trolley arms were located on guides on the inner faces of the fixed arms (see Figure 2). To operate the davits and lower the lifeboats, the lifeboat lashings were released and the telescopic trolley arm of the davit was hydraulically pushed out to the fully extended position. The lifeboat was then lowered to the embarkation deck and the davit arm brought back in to bring the lifeboat against the ship's side ready for boarding.

Lifeboats

3.3.4. The lifeboats supplied to the *Volendam* were designed and manufactured by Schat Harding and were of the MPC 36 SV partially enclosed lifeboat design. The lifeboats were constructed from marine-quality laminated glass fibre reinforced plastic; they had an overall length of 10.8 m and a beam of 4.45 m. The lifeboats weighed 5.45 tonnes (t) including loose gear, and had a capacity of 150 persons. The lifeboat release hooks were of the Tor T12 design and were 9.40 m apart in the stowed position.

² Holland America Line, M.V. *Volendam*, Lifeboat maintenance manual, provided by Fincantieri.

Wire falls

- 3.3.5. The lifeboat wire falls were of 22 millimetre (mm) 6x36 wire strand construction with an internal wire rope core. The wire falls had a minimum certified breaking strain of 390 kilonewtons. The forward fall was 90 m in length and the after fall was 81 m in length; they had been manufactured by Vornbäumen Stahlseile of Bad Iburg, Germany. They had been supplied to the *Volendam* in late 2005/early 2006 and fitted to number 7 davits on 28 November 2006.
- 3.3.6. The requirement under the International Convention for the Safety of Life at Sea 1974 (SOLAS) chapter III regulation 20 – operational readiness, maintenance and inspections paragraph 4 stated that:

Falls used in launching shall be inspected periodically with special regard for areas passing through sheaves, and renewed when necessary due to deterioration of the falls or at intervals of not more than 5 years, whichever is the earlier

Holland America Line had designated a renewal period for lifeboat falls of 4 years with routine inspections at regular intervals. The number 7 lifeboat forward fall had been fitted to the davit for more than 4 years. The vessel's management had noted that the wire fall was due for replacement, and on 24 November 2010, asked the vessel's fleet manager whether to proceed or defer until the vessel dry docked in March/April 2011 when other work was to be carried out on the davits. Fleet management agreed to defer the changing of the fall provided that "a visual inspection of the wires was done and if the wires appeared to be in good shape the replacement could be deferred until dry dock". On 29 November a visual inspection of the wires was recorded as having been undertaken.

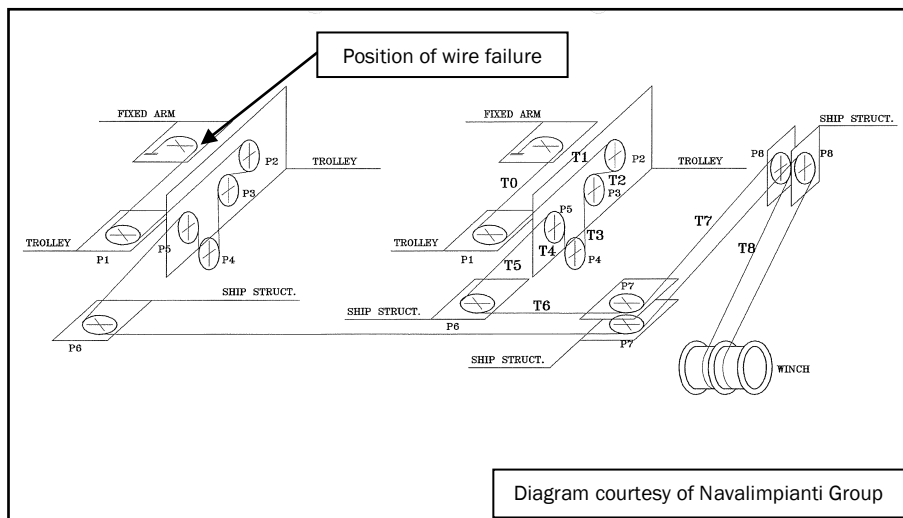

Figure 3
Wire fall reeving diagram

Since being fitted to number 7 davit, the fall had been greased on average every 6 weeks by ship staff using the recommended grease.

- 3.3.7. The wire falls were wound onto 2 hydraulically-driven winch drums and reeved through a series of sheaves located on the ship, on the telescopic trolley arms and on the fixed arms. Both wire falls terminated after passing around fixed guides located on the outboard end of the fixed arm of the davit (see Figure 3).

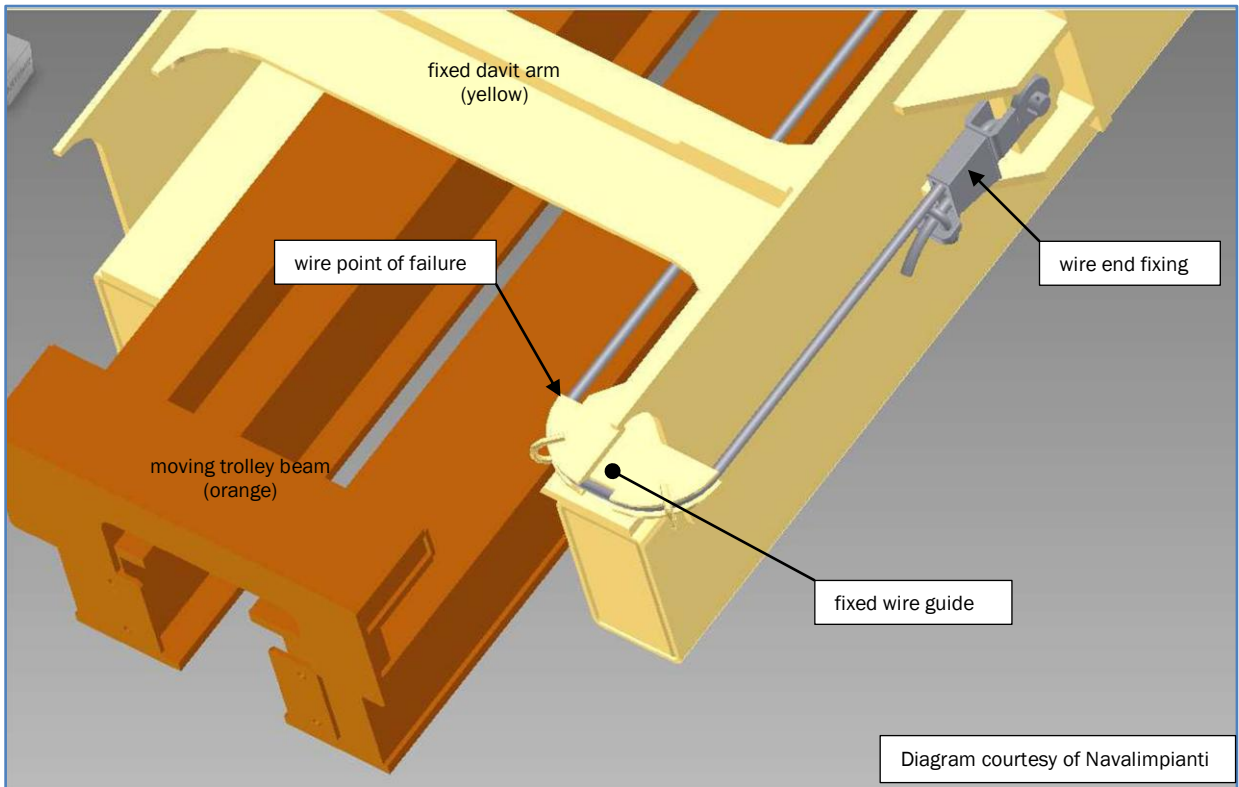

Figure 4
Diagram of davit construction

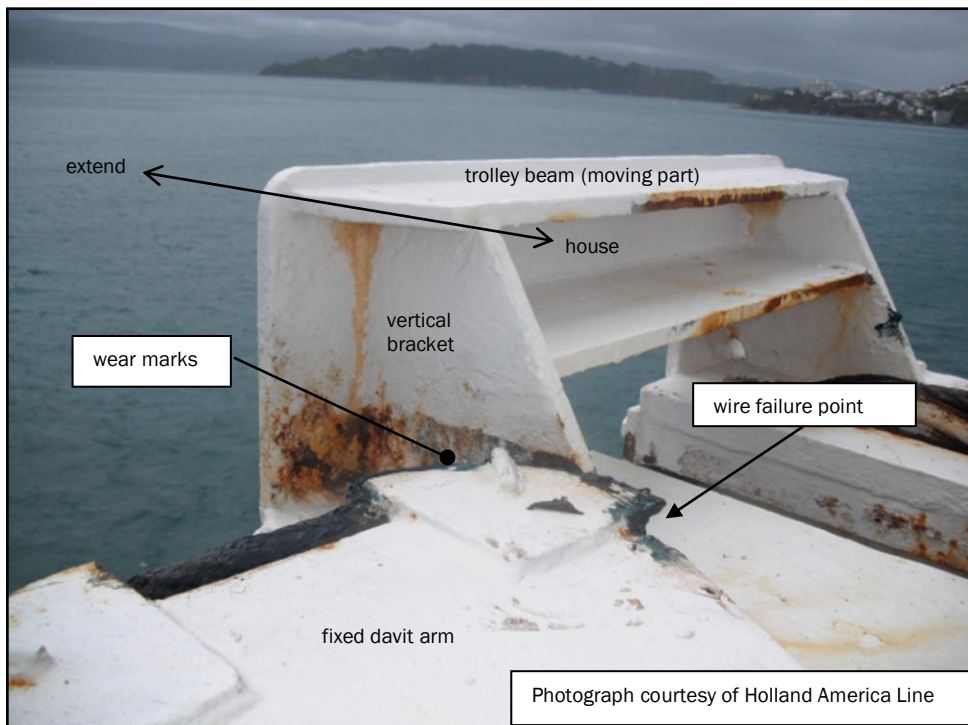

Figure 5
Number 7 forward davit showing moveable trolley beam and wire break point

3.4. Inspection and testing

Davit

- 3.4.1. After the accident, number 7 telescopic davit was re-housed in its stowed position with the fixed end of the forward wire fall still in place. This allowed the investigators to view the wire fall in place before it was removed.
- 3.4.2. The wire failed at a point just inboard from the end of the fixed guide on the inside of the forward davit arm (see Figures 4, 5 and 6). When being extended, and re-housed the moving trolley arm moved horizontally past this fixed guide. The groove on the fixed guide was of sufficient size to accommodate a 22 mm wire under tension. A vertical bracket on the moveable trolley beam lay adjacent to the fixed guide when the davit was in its stowed position.
- 3.4.3. Figures 4 and 5 show where the vertical bracket had been rubbing against the fixed guide, causing wear marks on the bracket. When number 5 davit was inspected, there was evidence of wire score marks on the bracket (see Figure 7).
- 3.4.4. When number 5 davit was tested during the inspection, the surveyor noted that when the weight of the lifeboat was taken on the falls there was an elastic deformation³ of the fixed davit arm of up to 15 mm inwards towards the moving trolley beam. On further inspection and measurement the surveyor noted that the fixed davit beam had an inward plastic deformation³ of about 10 mm (see Figure 8).

Wire fall

- 3.4.5. Both parts of the broken wire were sent to the Defence Technology Agency for independent examination and testing.
- 3.4.6. In Technical Memorandum C1191, provided to the Commission by the Defence Technology Agency about the failure of the number 7 davit forward fall, the Defence Technology Agency summarised as follows:

30. The wire rope was formed from galvanised steel wires. Its construction conformed to the documents sighted.
31. Surface wear was observed at several positions along the wire rope. Where present the wear did not significantly reduce the cross sectional area of the strands in question. No abrasive wear was observed within the lay or strands of the wire rope.
32. The failure had occurred in a severely corroded section of the hoist wire. A high proportion of the wires had corroded through and the corrosion had caused a significant reduction in the cross sectional area of other wires which finally failed by tensile fracture. This corrosion was associated with a relative absence of grease in the immediate area of the failure compared to that observed elsewhere.
33. Remote from the failure zone in the hoist section of the wire rope, general corrosion was seen on the surface of the visible wires. Sectioning and inspection of one discrete point on this part of the wire rope showed that only the outermost layers had been affected by corrosion which had not significantly reduced the cross sectional area of the wires or strand.

³ See glossary

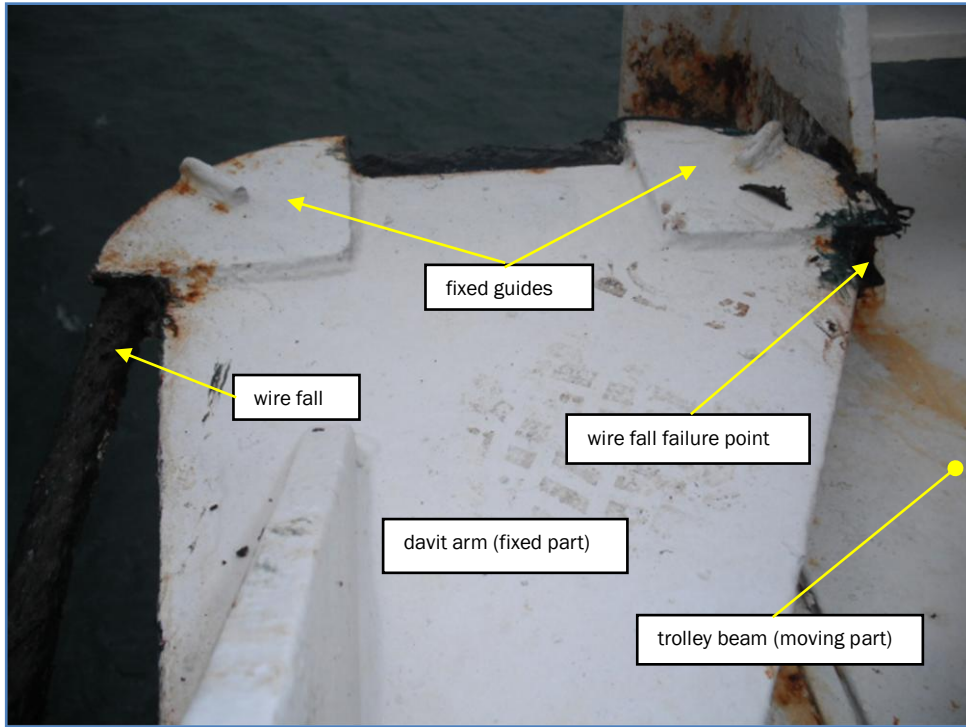

Figure 6
Head of number 7 forward fixed davit arm

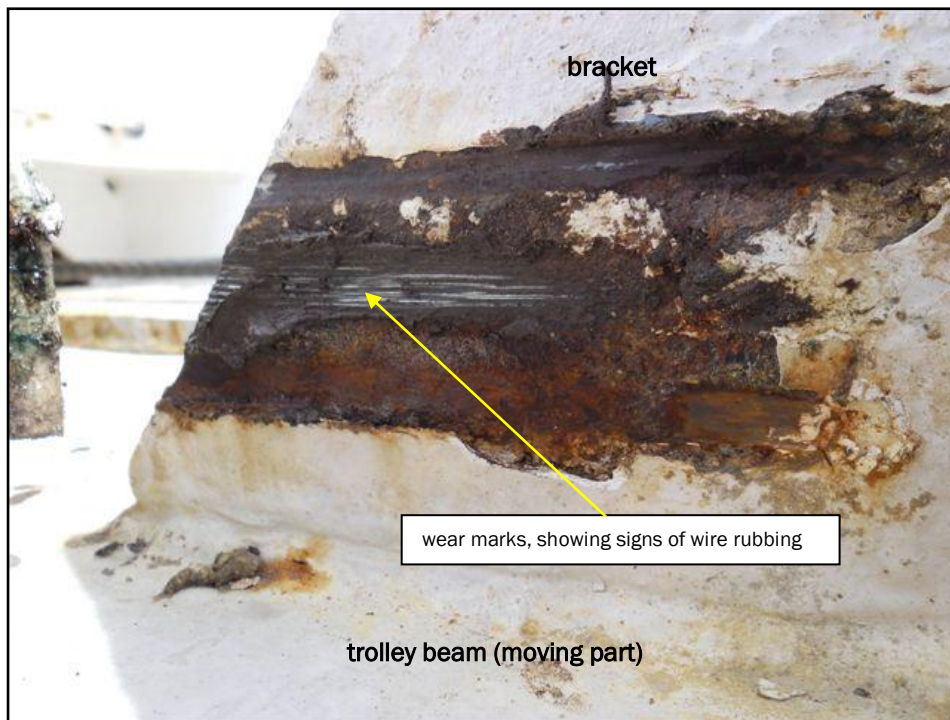

Figure 7
Vertical bracket from number 5 trolley beam

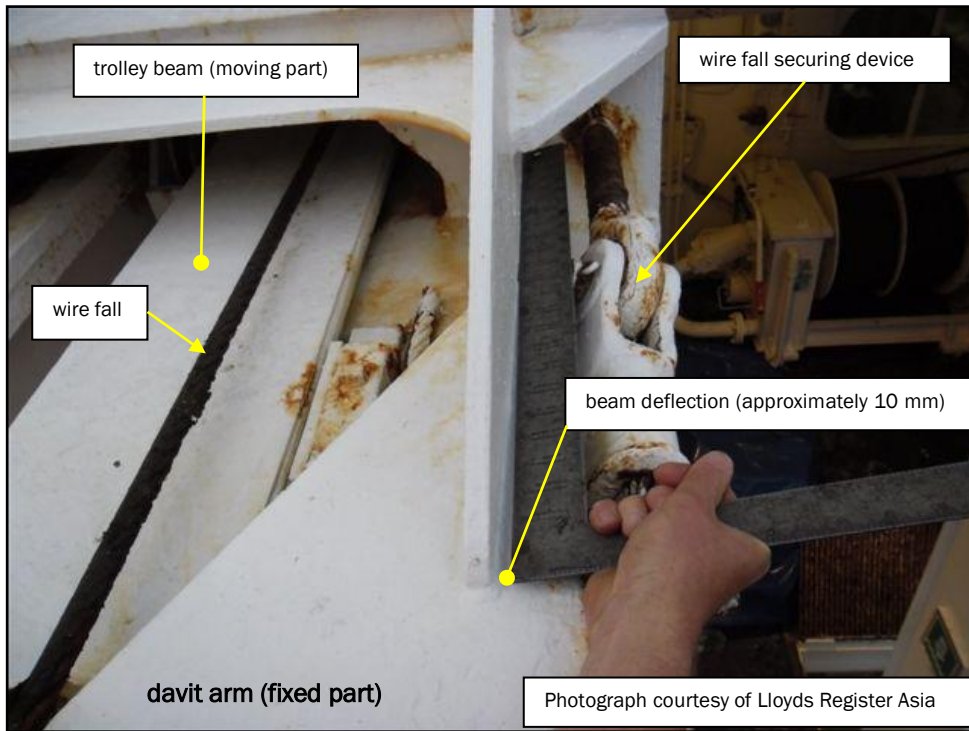

Figure 8
Number 5 davit beam (fixed part) showing deflection



Figure 9
Photograph of the failure point of number 7 lifeboat forward wire fall

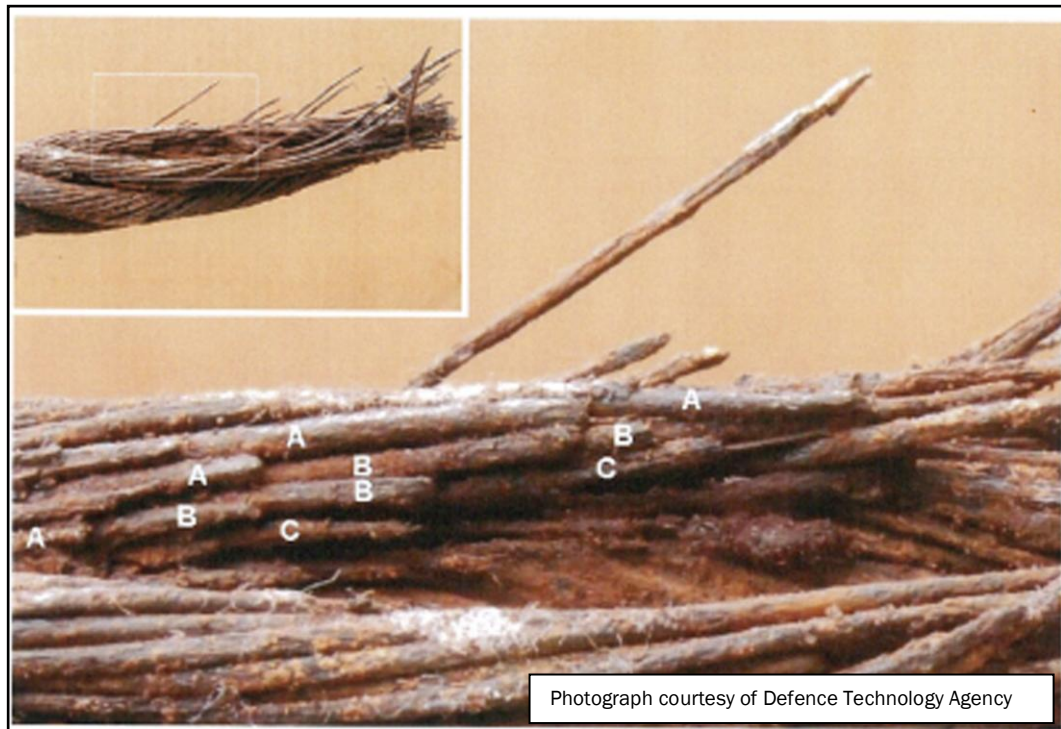

Figure 10
Enlarged photograph of failure point of number 7 lifeboat wire fall

3.5. Personnel information

- 3.5.1. One of the third officers on the *Volendam* had been designated as officer in charge of life saving appliances under the general supervision of the chief officer. This third officer had been employed by HAL since 2004 except for a short period in 2010. He had served on many of HAL's vessels and was currently on his second voyage on board the *Volendam*.
- 3.5.2. The "lifesaving" third officer was about to start some repairs on one of the starboard side lifeboats and was nearby when the alarm was raised. He immediately began readying the rescue boat for launching. He had kept the 0030 to 0430 watch on the morning of the accident and had not given the work orders to the crew, or conducted the "toolbox discussion" that day because he was still off duty and resting at the time they commenced work at 0800.
- 3.5.3. Lifesaving attendant one, had worked for HAL for about 18 months and was on his second contract. He had been appointed to the role of lifesaving attendant on board the *Volendam*. His duties included assisting with the maintenance and cleaning of all the lifeboats.
- 3.5.4. At the time of the accident lifesaving attendant one was working on the aft part of the lifeboat. He could swim and was the one who managed to keep afloat by holding onto a floating bucket of grease until he was rescued. After rescue he was taken to Christchurch Hospital where he was treated for minor bruising and mild hypothermia. He returned to the *Volendam* that evening before the vessel sailed for its next port.
- 3.5.5. Lifesaving attendant 2, was on his fourth contract with HAL and his second appointment on the *Volendam*. He had worked for HAL since June 2009 and had joined the *Volendam* on this occasion on the 1 September 2010. This appointment was his third appointment as lifesaving attendant in the HAL fleet and his second on board the *Volendam*. His duties included assisting with the maintenance and cleaning of all the lifeboats.
- 3.5.6. At the time of the accident he was working on the forward part of the lifeboat. It was reported that he could not swim.

- 3.5.7. Lifesaving attendant 3 had joined the *Volendam* on 5 June 2010. At the time of the accident he was stationed on the lifeboat operating platform by the hydraulic controls for the winch and telescopic arm.
- 3.5.8. Lifesaving attendant 4 had been helping the other lifesaving attendants with the wire greasing, but at the time of the accident had gone to lower number 9 tender lifeboat to the embarkation deck so that the lifesaving third officer could carry out some maintenance on it.

3.6. On board working practices

3.6.1. The *Volendam* had a documented working scheme and a workspace safety manual; Marine Regulation 600 (MR600). MR600 formed part of the safety management system and was a policy and procedures document applying to all marine operations of Holland America Line.

3.6.2. Chapter 3 of MR600 dealt with accidents and stated in the introduction:

Job hazard analysis (JHA) is a basic tool used for safe job planning. It is a simple process used to develop safe job procedures and train employees. The JHA technique allows the work crew to think through the steps of the job, discuss the potential hazards of each step and to identify precautions to eliminate or minimize the hazard. It requires input from everyone who participates in the job. A JHA can be either in a written form or conducted verbally.

In developing a JHA, use the guidance provided elsewhere in this Marine Regulation. For example, if one of the identified hazards is the possibility of the crew member falling, refer to the Fall Protection Program in Section 8 of this MR to determine the best means to address the hazard.

3.6.3. Two JHA sheets were applicable to the work being undertaken by the lifeboat attendants at the time of the accident. They were JHA-0001 working aloft and outboard (see Appendix 3) and JHA-0009 wire greasing (see Appendix 4). JHA-0001 noted that a working aloft permit (see Appendix 5) needed to be completed.

3.6.4. Before any work task was undertaken by the ship's crew a "toolbox discussion" was required to be held between those carrying out the work and the supervisor. The purpose of this discussion was to talk about the job that was to be done, so that all participants had a clear understanding of the potential hazards in carrying out the job, what permits were required, whether JHA sheets were available and what personal protective equipment (PPE) was to be used. A form noting that this "discussion" had taken place was required to be filled out and signed by all participants (see Appendix 6).

3.6.5. On this occasion the "Toolbox Discussion form" had been completed and signed by the 4 lifesaving attendants, but not by a supervisor. Of the 3 surviving lifesaving attendants, one thought the discussion had been led by the third mate (who was off duty and resting), one thought the chief officer had led the discussion and the other was not questioned. The form did not have the lifejacket and safety harness icons ticked as being applicable to the job, and it erroneously referred to working on the port side lifeboats instead of the starboard side where the work was occurring. Whether a proper toolbox discussion took place is discussed in the analysis section of this report.

3.7. Maintenance regime

3.7.1. The maintenance regime on board the *Volendam* was controlled through a comprehensive third party computer-based maintenance management system. The software allowed users to plan and schedule work assignments for planned and condition-based maintenance. The system was recognised by all major classification societies and when used properly complied with the requirements of the International Management Code for the Safe Operation of Ships and for Pollution Prevention (ISM code).

3.7.2. The ISM code was incorporated into SOLAS as chapter XI of the convention in 1993 and became mandatory in 1998. The ISM code established safety management objectives and required a safety management system to be established by the company operating the vessel. The company was then required to establish and implement a policy for achieving these

objectives, including the necessary resources and shore based support for vessels the company operated.

- 3.7.3. The maintenance database showed that the number 7 davit wires and other components had been greased at regular intervals of about 6 weeks. The database also showed that between 8 August and 18 August 2010, the vessel had undergone an annual thorough examination of lifeboat davits and winches and hydraulic winch brake tests in compliance with SOLAS chapter III. This examination was carried out by the davit manufacturer's representatives.
- 3.7.4. The manufacturer's representatives completed a checklist on the condition of the davits and equipment. This checklist noted that for number 7 davits the travelling wire ropes needed adjustment and greasing, and that the hoisting wires were in good condition but needed greasing. The travelling wire ropes were adjusted by the manufacturer's representatives at the time.
- 3.7.5. The travelling and hoisting wire ropes had, according to the database records, been greased on 2 September 2010, and since then had undergone 9 inspections and checks but had not received any maintenance or greasing since that date.
- 3.7.6. A set of bottle-screw devices (referred to as 'manutensioning' devices) was supplied by the manufacturer that could be used to hang the lifeboat from the fixed arms of the davit. The moveable trolley could still be telescoped out but the lifeboat remained inboard. In this way the tension on the wire falls would be released, allowing components such as sheaves, guides and the like to be serviced. Hanging the boat off in this fashion would allow the wires to be prised out of the guides on the end of the fixed arms so that they could be inspected and greased, but this was difficult to achieve without the lifeboat underneath to provide the work platform.
- 3.7.7. A 'panama' link was also provided whereby the boat could be hung from the moveable trolley. This link was supplied to enable the lifeboats to be moved further inboard than normal to allow the ship to transit the Panama Canal. The hanging off link was not designed to be used as a maintenance device and was not used during routine maintenance and greasing on board the *Volendam*; instead the inspection and greasing of the wire were always undertaken with the wire under tension from the weight of the lifeboat. With the wire under tension it was not possible to inspect visually the inside of the wire where it passed around the guides on the end of the fixed arm before terminating at the wedge socket connection.

3.8. Survival aspects

- 3.8.1. Each member of the crew involved in the work of greasing the wires was clothed in their normal working attire of a cotton windproof jacket, overalls, T-shirt, undergarments, socks and boots.
- 3.8.2. The weather conditions at the time were an air temperature of about 15 degrees Celsius (°C) and a wind coming from a south-westerly direction at a speed of about 12 knots [6.17 metres per second] The average sea temperature for February, the warmest month, was 16°C in the Lyttelton area (United Kingdom Hydrographic Office, 2007), which was about what the sea temperature was at the time of the accident.
- 3.8.3. Each member of the crew working outboard of the vessel's rail on the top of the lifeboat was wearing an appropriately fitted and adjusted safety harness with a 1.83 m impact strop attached at the back. The other end of the impact strop was attached to a polypropylene rope strung taut between the 2 lifeboat fall wire blocks.
- 3.8.4. The position where the lifesaving attendants one and 2 were working on the top of the lifeboat cabin was calculated to be about 16 m above the water level.

3.8.5. When anyone falls into water that is cold they can suffer from a phenomenon called cold water immersion. Wilderness Medicine (Steinman A, 2001) states that the definition of cold water is variable; however, for practical purposes a significant risk for immersion hypothermia usually begins in water colder than 25° C, so it uses 25° C as the definition of cold water. The book goes on to say:

... The body's responses to cold-water immersion can be divided into three phases:

1) initial immersion and the cold-shock response;
2) short-term immersion and loss of performance; and
3) long-term immersion and the onset of hypothermia. Each phase is accompanied by specific survival hazards for the immersion victim from a variety of pathophysiologic mechanisms.

Deaths have occurred in all three phases of the immersion response ...

... Phase 1: Initial Immersion and the Cold Shock Response:

The cold shock response occurs within the first 1-4 minutes of cold water immersion and is dependent on the extent and rate of skin cooling. The responses are generally those affecting the respiratory system and those affecting the heart and the body's metabolism. Rapid skin cooling initiates an immediate gasp response, the inability to breath-hold, and hyperventilation. The gasp response may cause drowning if the head is submersed during the initial entry into cold water. Subsequent inability to breath-hold may further potentiate drowning in high seas. Finally, hyperventilation causes arterial hypocapnia, which leads to decreased brain blood flow and oxygen supply. This may lead to disorientation, loss of consciousness and drowning.

Skin cooling also initiates peripheral vasoconstriction as well as increased cardiac output, heart rate and arterial blood pressure. The increased workload on the heart may lead to myocardial ischemia and arrhythmias, including ventricular fibrillation. Thus, sudden death can occur either immediately or within a matter of minutes after immersion (i.e., due to syncope or convulsions leading to drowning, vagal arrest of the heart, and ventricular fibrillation) in susceptible individuals.

3.8.6. As mentioned previously, the deceased was not wearing a lifejacket. The post-mortem examination showed that he had suffered moderate bruising to the head and 2 fractured ribs. The pathologist listed the cause of death as drowning complicating moderate injury.

4. Analysis

4.1. Introduction

- 4.1.1. Steel wire ropes are used on numerous devices on board ships; cranes and other lifting devices, and launching devices for the variety of live saving apparatus to name a few. The salt water marine environment is harsh on steel wire, and wire failure owing to internal corrosion is not a new event.
- 4.1.2. As well as the question of why the wire fall failed, this report looks at 5 other issues that contributed to the accident in some way. These issues are discussed in the following order:
- why the lifeboat fall failed
 - why the crew fell into the sea
 - the importance of wearing life jackets when working over water
 - the issue of crew violating good company procedures
 - incorporating maintenance into davit design.

4.2. Why the lifeboat fall failed

- 4.2.1. The ends of the davits where the fall wires passed around the fixed guides were located outside the ship's rail when the lifeboats were in the stowed position, which made access to them for maintenance difficult (see Figure 11). The easiest and preferred means for the crew was to extend the lifeboat out until it was under the ends of the fixed davit arms and use the lifeboat's cabin roof as a work platform.

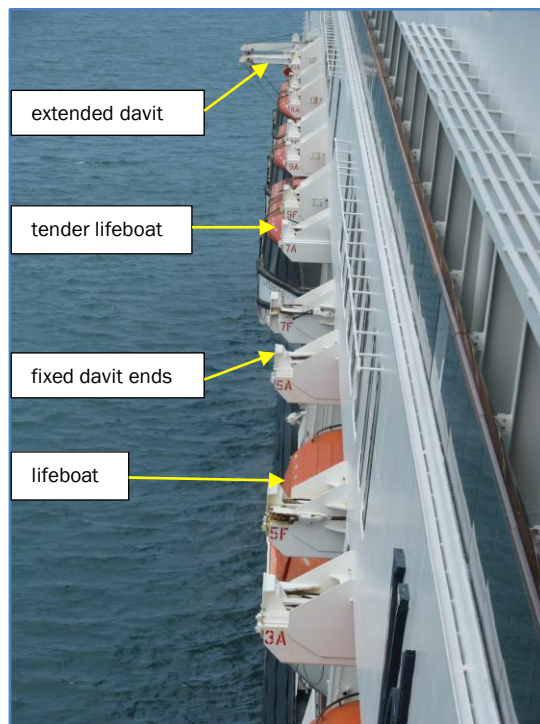

Figure 11
Starboard side of the Volendam looking aft from the navigating bridge showing position of davit ends and stowage positions

- 4.2.2. The problem was that with the boat extended out in this fashion the lifeboat fall wires were under tension, so the wire could not be eased out of the guide for inspection or greasing. The maintenance instructions from the manufacturer neither highlighted this problem nor offered a solution.

- 4.2.3. Judging by the condition of the wire where it failed, and the condition of the wire falls at the same location on the other lifeboats, these sections of the lifeboat wires where they passed around the fixed guides had not been inspected or lubricated, with the exception of the grease that was applied to the outside of the wire where it was visible within the guides, for over 4 years in this case. .
- 4.2.4. Salt-laden water was then easily able to penetrate the core of the wire from the inside of the guide, and in the absence of lubricant the corrosion process accelerated. The fall wire failed when the corrosion weakened it to a point where it could no longer support the weight of the lifeboat. The wire failed in tension overload.
- 4.2.5. The state of the failed wire and other wires on the remaining boats would have been evident had a thorough inspection been made. The Commission is surprised that successive “thorough” inspections by the ship’s crew and by the manufacturer’s representatives only 5 months before the accident, had not recognised the potential danger in not inspecting the complete wire. A wire is only as good as its weakest part, which is why seamen are trained to inspect all parts of a wire thoroughly during maintenance and annual “thorough inspections”.
- 4.2.6. Most lifeboat installations have standing parts that can be difficult to inspect or to which it is difficult to apply grease. Apart from releasing the wire tension to enable proper inspection, there are other methods of mitigating the risk. It used to be a requirement to end-for-end lifeboat falls so that at-risk parts of the wire were located elsewhere in the rigging. This is still a voluntary option but is more difficult to achieve. Some operators opt to start with longer wires and progressively shorten them during the 4 to 5 year lifespan of the wires. This achieves the same result for less effort, moving the prone sections of wire to another location where they can be inspected and lubricated. The design of the lifeboat davit and associated equipment facilitated a thorough inspection and greasing of the complete wire, but the routine operation for inspecting and greasing the lifeboat falls on the *Volendam* did not make best use of the equipment provided by the manufacturer which would have allowed the weight of the lifeboat to be taken off of the wire.

Findings

The wire rope lifeboat fall failed owing to corrosion of the internal wire strands, brought about by a lack of lubrication of the standing part of the wire where it passed around the guide near the terminus of the fall.

The section of wire that failed had not been thoroughly inspected or adequately lubricated during the 4 years it had been in service.

The design of the lifeboat davit and associated equipment facilitated a thorough inspection and greasing of the complete wire, but the routine operation for inspecting and greasing the lifeboat falls on the *Volendam* had not made best use of the equipment provided by the manufacturer, which would have allowed the weight of the lifeboat to be taken off the wire.

4.3. Why the crew members fell into the sea

4.3.1. The failure of the wire and the sudden dropping of the lifeboat bow left little opportunity for the crew to hold on, so they were totally reliant on their safety harnesses. Both crew members who fell into the water were wearing the correct safety harnesses and lanyards. They had strung what should under normal circumstances have been an adequate safety line between the lifeboat forward and aft suspension hooks. These hooks were of sturdy construction and were arguably the strongest points on the lifeboat.

4.3.2. The safety line was sufficient in strength and length, having been tied taut between the suspension hooks. The safety line would have been adequate to take the load should one or both of the crew members have slipped and fallen.

- 4.3.3. The failure of the lifeboat forward fall wire caused the lifeboat to pivot around the after suspension hook, forcing the hook through the hull of the lifeboat. The resulting spread of the lifting hooks (see Figure 12) causing the safety line to break would not have been easy to foresee.
- 4.3.4. The hazard now, however, has been identified and the company needs to devise an alternative method of connecting safety harnesses. The manufacturer has devised such a system using a wire spanning the davit heads with “fall arrestors” attached, to which safety harnesses are connected.

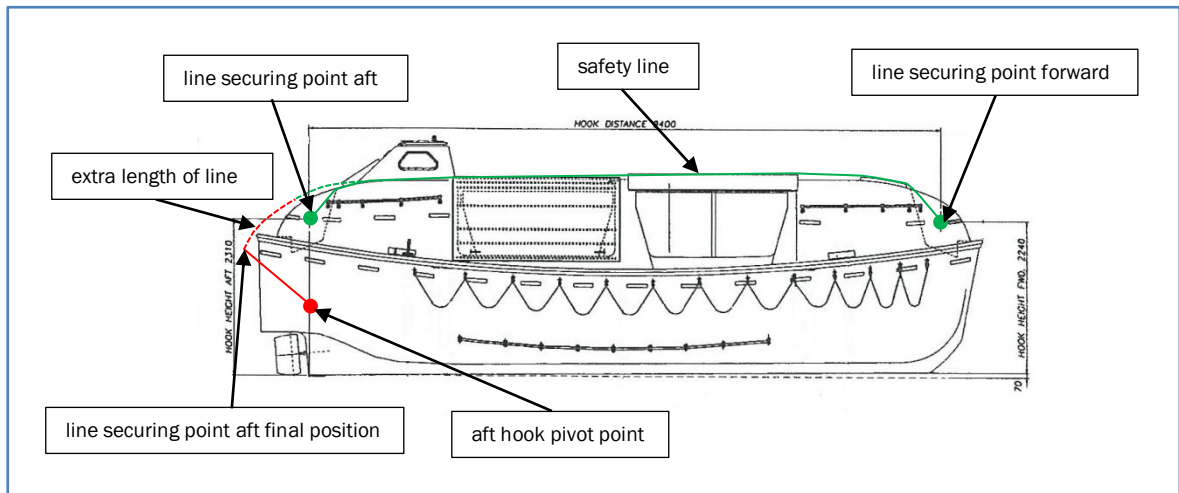

Figure 12
Diagrammatic representation of aft fall hook failure

Findings

The safety line rigged between the 2 lifting hooks stretched and broke because the aft lifting hook was damaged when the front of the lifeboat dropped. The crew fell to the sea because their safety harnesses were attached to the safety line that broke.

The safety harness arrangement should under normal circumstances have been adequate to arrest the inadvertent fall of both crew members. The dynamics of the lifeboat fall and the effect on the safety harness arrangement would have been difficult to foresee.

4.4. The importance of wearing lifejackets when working over water

- 4.4.1. Both crew members were wearing similar clothing, overalls, undergarments, socks, work boots and blue windcheaters. These clothes would have quickly become waterlogged and the boots filled with water, weighing them down. One managed to grab a partially full plastic grease bucket, affording him some extra buoyancy to stay afloat. The other crew member was unable to reach and hold on to any flotation aid, including life-rings that were thrown to him, and was unable to keep himself above water. He succumbed before the rescue vessel could reach him.
- 4.4.2. The water temperature was about 16° and both crew members who fell into the water could have suffered a cold-shock response to some extent. A swimmer might be better able to cope with this phenomenon.
- 4.4.3. The crew member who could not swim suffered moderate head and chest injuries in the fall to the sea. In the absence of any signs of external trauma, such injuries are consistent with impacting on the water from a height of about 16 m. He was seen by the crew to be dazed but conscious. These injuries were in themselves not life-threatening, so had he been wearing a personal flotation device as he was supposed to, it is more likely that he could have kept his head above water, even in his dazed state.

- 4.4.4. It is a matter of speculation whether all of the factors mentioned above contributed to the crew member drowning. One thing that can be said with certainty is that if the deceased had been wearing a personal buoyancy aid his chances of survival would have markedly increased.

Findings

Neither of the crew members who fell into the water was wearing any form of personal flotation device. A personal flotation device would have increased the chance of the second crew member surviving.

The second crew member's ability to stay afloat was compromised by his inability to swim, the possibility of cold shock and his dazed state brought on by the injuries he received during the fall, none of which should have been life-threatening had he been wearing a personal flotation device.

4.5. Violation of good company procedures

- 4.5.1. The safety management system of HAL included a policy and procedures document that applied to all marine operations of HAL. MR600 formed part of this system. Although the system as a whole was robust and comprised checks and balances throughout to mitigate chances of error, the crew did not follow it on this occasion.
- 4.5.2. The crew not following MR600 is considered a violation, which has been described as “a deliberate deviation from an organisation's safety procedures that have been drawn up for the safe or efficient operation and maintenance of plant or equipment” (Health and Safety Executive UK, 1995). “Even though violations are deliberate breaches, many of them are conducted with good intentions to assist the organisation to meet its objectives for example ...” (Mason, 1997). Violations typically reflect a social/motivational phenomenon rather than an information processing problem.
- 4.5.3. In this case the non-wearing of personal flotation devices appeared to be an exceptional violation. “Exceptional violations appear as isolated departures from authority, not necessarily indicative of individuals' typical behaviour pattern nor condoned by management” (Reason, 1990). They are not considered exceptional because of their extreme nature; rather they are considered exceptional because they are neither typical of the individuals nor condoned by authority. What makes exceptional violations particularly difficult for an organisation to deal with is that they are not indicative of individuals' behavioural repertoire and, as such, are particularly difficult to predict. Usually when individuals are confronted with evidence of their behaviour and asked to explain it, they are left with little explanation (Shappell & Wiegmann, 2000). This was not dissimilar to the surviving crew member on the *Volendam* when interviewed after the event; he was aware that they should have been wearing lifejackets but was at a loss to explain why they were not.
- 4.5.4. MR600 complied with the documentation for the requirements for workplace safety under De Arbeidsomstandighedenwet 1996 (Dutch law), Bahamian law, ISM and company policy. It included sections on accident prevention, occupational workplace safety training, JHA and work procedures and systems. The JHA section included the responsibilities for crew members, supervisors and overall programme monitoring. The sections on the fall protection programme and the use of personal flotation devices included 4 references to working over the side of the ship and at heights and the need for personal flotation devices and working aloft permits.
- 4.5.5. Although MR600 included references to the use of life jackets or personal flotation devices, the JHA sheets were not clear on the requirement. The JHA sheet for working aloft and outboard contained a reference to a work vest (see Appendix 3). This work vest was one of the 5 types of personal flotation devices mentioned in MR600; however, the ambiguity in the wording between the documents could cause confusion especially to a crew member not fluent in English. This is an improvement that could be made to the JHA sheets.

Notwithstanding this point, the crew were familiar with the task and knew that they were supposed to wear work vests (personal flotation devices).

- 4.5.6. JHA sheets 0001 and 0009 clearly identified the correct personal protective equipment to be used and the permits required (see appendices 3 and 4). A correct working aloft permit was completed as required for the correct day, time and area of operation (see appendix 5). The JHA's also direct personnel to consult both MR 600 and the relevant chapter in the Code of Safe Working Practices consolidated edition 2007 as published by the United Kingdom Stationery Office. There was therefore more than sufficient reference to the need to wear personal flotation devices when working outboard, regardless of whether safety harnesses were being worn or not.
- 4.5.7. The safety system included a verbal JHA or "toolbox discussion" before work commenced. MR600 covered this in section 3.6:

Verbal JHAs are also referred to as pre-job or "tool box" discussions. They are intended to get crew members focused on the job that they are about to perform. The greatest benefit comes from the crew member identifying the steps of the job, recognizing the potential hazards, and planning to eliminate or reduce those hazards. It is important that supervisors ensure and encourage active participation from the crew and resist the temptation to merely inform them about the tasks that they are about to perform. Of course, if a potential hazard is overlooked by the crew members it should be pointed out by the supervisor.

The toolbox discussion that was said to have taken place on 8 January before the wire greasing took place, if it took place at all, was ineffective at least. Certain features about the completion of the Toolbox Discussion form (see Appendix 6) that was given to the Commission after the accident were noted in that:

- the date had been manually amended to the correct date of 8 January 2011; this may have been a typographical error or an omission to change the date from the previous day, before printing the form
- the job description noted that the job was to continue greasing the PS [port side] lifeboat travelling wires **not** the starboard side. This could be a similar omission as noted above
- the form **did** note that a permit was available and that JHA's were available and a potential hazard was falling in the water
- the form **did** note that gloves, signs and barriers, and heavy lift precautions should be utilised; however
- the form **did not** note that hard hats, boots, harnesses and personal flotation devices should be used
- although the form **was** initialled by the crew members it **was not** initialled or signed by the supervisor to indicate that the "discussion" had taken place, or that the PPE usage had been verified.

The Commission considers it unlikely that a proper tool box discussion took place. If the discussion did not take place, the supervisor would probably not have checked the usage of the PPE. This possibility is further supported by the crew members' different recollection of who the supervisor was; one believing it was the third officer, who was off duty and resting at the time.

- 4.5.8. Had the supervisor checked the usage of the PPE the lack of personal flotation devices should have been apparent. Nevertheless, the purpose of the toolbox discussion was for the crew members to recognise the potential hazards, and plan to eliminate or reduce those hazards. The crew members had carried out this task before. They should have had this toolbox discussion on each occasion and been able to identify for themselves the correct PPE, and the need for personal flotation devices.

Findings

The safety management system on board the *Volendam* and the subsidiary JHA made for the task of greasing the lifeboat wires were robust and if followed by the crew on the day would have helped to prevent the death of the crew member when the lifeboat fall failed.

A proper toolbox discussion prior to starting the task for the day probably did not take place, which was a lost opportunity to ensure that crew conducting the task wore buoyancy aids.

The crew members conducting the task were aware that they were supposed to wear buoyancy aids when working outside the rail, and regardless of whether a toolbox discussion took place or not, must bear some responsibility for not complying with the instruction.

4.6. Design and maintenance of the lifeboat launching davit

- 4.6.1. The design of an installation is more than just the mechanics that make it work. The systems and procedures for maintaining it in good order form part of the design as well.
- 4.6.2. The design of a lifeboat davit is often a compromise between efficient functioning and ease of maintenance. The lifeboat davit manufacturer designs a davit that must receive several different lifeboat designs, as well as fit many different ship designs. Passenger ships are usually slab-sided with the lifeboats housed in purpose-built recesses, just like on the *Volendam*.
- 4.6.3. Inevitably there will be parts of a lifeboat davit exposed to the elements, even one that is housed within a recess. The ends of the fixed arms of the *Volendam*'s davits, where the fall wires passed around the fixed guides were an example of that. The davit ends protruded outside the rail of the ship, were high up and were therefore difficult to access.
- 4.6.4. The manufacturer provided equipment to enable most parts of the davit to be inspected and serviced, but none of these arrangements enabled a thorough inspection of the wire where it passed around the fixed guides. The crew could access the area by standing on the roof of the lifeboat with it telescoped out, but could not release the tension on the wire to allow it to be prised out of the guides for inspection and lubrication. A method was provided for releasing the tension on the wires, but not when the lifeboat was telescoped out to provide a work platform.
- 4.6.5. Ironically, the manufacturer had provided a device that could have achieved both access and release of wire tension, but this device was designed for a different purpose: to retract the boats further inboard so that the ship could transit the Panama Canal. Consequently the process was not documented as one to be used for maintenance, and was not used as such on board the *Volendam*.
- 4.6.6. The maximum lifetime of the wire falls was 5 years, reduced to 4 years by the operator. Four years was too long for part of a wire to go without lubrication and without inspection. This should have been obvious to those maintaining and inspecting the wire, including the manufacturer's technicians who conducted the annual "thorough" inspection. The crew diligently applied grease to the visible part of the wire where it went around the fixed guides, which would have given the appearance of a well maintained wire, masking the corrosion that was happening within.
- 4.6.7. There were options to address the problem. A system of hanging the lifeboat off the trolley in a similar manner to the Panama Canal link would have been one option, and this is now offered and recommended by the manufacturer in response to this accident.
- 4.6.8. Other options would have been to shorten the wire periodically by pulling it through so that a different section of wire was enclosed in the fixed guides, to use stainless steel wire, and to install grease nipples within the fixed guides. There are no doubt other solutions to the

problem, such as accessing the davit ends from the wharf with the aid of a shore based boom lift or “cherry picker”, as was done during the post-accident inspection of the remaining davits.

- 4.6.9. The inspection of the davit systems after the accident showed that the design of the davits for the lifeboats was different from that of the davits for the rescue boats and tender lifeboats. When the weight of the lifeboat was taken by these davits, an inward elastic deformation of the fixed arm towards the trolley beam was noted. Over time this inward elastic deformation when under load had caused a plastic deformation of between 5 mm and 15 mm towards the trolley beam.
- 4.6.10. The trolley beam had a vertical face plate at the outer end fixed by 2 triangular metal brackets; the plastic deformation in the fixed arm could cause the triangular metal brackets to rub against the fall wire guides on the fixed arm. If for whatever reason the wire rather than the guide made contact with the triangular brackets, the applied protective coating could be worn away, allowing the ingress of water or in extreme cases wearing the fall wire itself.
- 4.6.11. The trolley beam ran in and out on rollers fitted into guides on the fixed arm. The trolley beam top bar also ran on horizontal and vertical grease-impregnated nylon bearing pads fitted to the fixed arms. Wear in the vertical pads would allow the trolley beam to move within the fixed arms and increase the chances of the triangular metal brackets contacting the fall wire guide and fall wire.
- 4.6.12. The deformation of the fixed davit arms under load may or may not have contributed to this wire failure. If the resulting contact between the vertical bracket and the wire had not damaged the wire, it could at least have scraped the protecting grease from the wire, thus accelerating the ingress of water and internal corrosion. This was observed to be the case with number 5 davit.
- 4.6.13. The manufacturer has alerted ship owners to the potential problem and offered a modification to address it (see response to safety recommendations).

Findings

The design of the lifeboat davit did not allow easy maintenance of the wire fall where it passed around the guides on the end of the fixed davit arm, and this problem had gone unnoticed or ignored during the 10-year life of the vessel.

The fixed arm of the lifeboat davits bending in and contacting the movable trolley had the potential to contribute, and may have contributed to the wire failure.

5. Findings

- 5.1. The wire rope lifeboat fall failed owing to corrosion of the internal wire strands, brought about by a lack of lubrication of the standing part of the wire where it passed around the guide near the terminus of the fall.
- 5.2. The section of wire that failed had not been thoroughly inspected or adequately lubricated during the 4 years it had been in service.
- 5.3. The design of the lifeboat davit and associated equipment facilitated a thorough inspection and greasing of the complete wire, but the routine operation for inspecting and greasing the lifeboat falls on the *Volendam* had not made best use of the equipment provided by the manufacturer, which would have allowed the weight of the lifeboat to be taken off of the wire.
- 5.4. The safety line rigged between the 2 lifting hooks stretched and broke because the aft lifting hook was damaged when the front of the lifeboat dropped. The crew fell to the sea because their safety harnesses were attached to the safety line that broke
- 5.5. The safety harness arrangement should under normal circumstances have been adequate to arrest the inadvertent fall of both crew members. The dynamics of the lifeboat fall and the effect on the safety harness arrangement would have been difficult to foresee.
- 5.6. Neither of the crew members who fell into the water was wearing any form of personal flotation device. A personal flotation device would have increased the chance of the second crew member surviving.
- 5.7. The second crew member's ability to stay afloat was compromised by his inability to swim, the possibility of cold shock and his dazed state brought on by the injuries he received during the fall, none of which should have been life-threatening had he been wearing a personal flotation device.
- 5.8. The safety management system on board the *Volendam* and the subsidiary JHA made for the task of greasing the lifeboat wires were robust and if followed by the crew on the day would have helped to prevent the death of the crew member when the lifeboat fall failed.
- 5.9. A proper toolbox discussion prior to starting the task for the day probably did not take place, which was a lost opportunity to ensure that crew conducting the task wore buoyancy aids.
- 5.10. The crew members conducting the task were aware that they were supposed to wear buoyancy aids when working outside the rail, and regardless of whether a toolbox discussion took place or not, must bear some responsibility for not complying with the instruction.
- 5.11. The design of the lifeboat davit did not allow easy maintenance of the wire fall where it passed around the guides on the end of the fixed davit arm, and this problem had gone unnoticed or ignored during the 10-year life of the vessel.
- 5.12. The fixed arm of the lifeboat davits bending in and contacting the movable trolley had the potential to contribute, and may have contributed to the wire failure.

6. Safety actions

- 6.1. The Commission classifies safety actions by 2 types:
- (a) safety actions taken by the regulator or an operator to address safety issues identified by the Commission during an inquiry that would otherwise result in the Commission issuing a recommendation; and
 - (b) safety actions taken by the regulator or an operator to address other safety issues that would not normally result in the Commission issuing a recommendation.

Safety actions addressing safety issues identified during an inquiry

- 6.2. On 11 January 2011, Holland America Line's Fleet Operations issued a Fleet Alert: FA 002-11 on the subject of lifeboat davit systems – one time inspection, the purpose of which was to:
- conduct a one-time inspection of all lifeboat davit systems, verify that hoisting wire falls are in proper condition, reiterate fall protection procedures and the use of personal protective equipment
- 6.3. On 18 January 2011, Carnival Corporation & PLC (the parent company of Holland America Line) issued an advisory notice No. 02/2011 which recommended to each of its subsidiary cruise lines that they:
- 1. Inspect all lifeboat, tender and rescue boat wire falls for any abnormalities (fish hooks, corrosion, cuts, abrasion etc) with particular attention to areas where the wires may be subject to friction against fixed or moving structural components of the hoisting systems.
 - 2. Examine all sheaves, guides, links, hooks, thimbles and wire securing points of the hoisting system for any abnormalities such as corrosion and excessive wear and to ensure proper functionality. During such inspections the hoisting system should be moved in various positions as designed.
 - 3. Review its policies and procedures covering working aloft to assess their adequacy, with particular emphasis to the use and maintenance of fall prevention devices and the related training provided to shipboard personnel.
 - 4. Assess the adequacy of its requirements for the use of personal flotation devices applicable to personnel working over the ship side and reiterate the importance of using such devices to line workers and their supervisors.
- 6.4. On 17 March 2011 the Chief Executive of Navalimpianti Tecnimpianti Group advised the Commission that:
- (a) presently our company is offering to the owners of vessels fitted with our davit systems the following safety equipment.
 - 1) A safety stainless steel span wire on which the personnel involved in the inspections or maintenance operations can hook the specific individual safety device.
 - 2) Two additional eyes, one for each of trolley beams, to which the boat can be fastened by means of a short lifting fiber lines during the inspection and maintenance operations. These pad eyes already exist on all tender davits for the pendant recovery stops. Using these existing devices as a safety means for inspections and maintenance operations, it is only necessary to hang the boat to these lifting eyes by two shorter stops, in way to reduce the free falling height to some centimeters only.

- 3) We have also received information of another wire rope failure in an older davit type due to corrosion on a running wire rope section. The relevant investigation pointed out that the wire rope was greased after the corrosion began and consequently the routine visual inspections of the rope did not notice this corrosion.

After the failure, the wire rope was cleaned, discovering the true status of the corrosion. For this reason we recommend, that to improve the reliability of the inspection and maintenance operations a check of the wire rope lengths that remain for long periods inside the davit arms and pulley boxes with magnetic instrumentation.

This check may be scheduled with a frequency of 6 or 12 months and, for example, for a complex telescopic davit may require approximately half day. Our Company can perform these checks which in conjunction with the existing computerized instrumentation can show all broken wires and also the reduction of the rope section due to the corrosion status.

6.5. On 28 September 2011 Holland America Line, in response to the draft final report noted that the following actions were being taken in response to the accident.

- the davit end supporting brackets on the *Volendam* and *Zaandam* were being upgraded to mitigate the risk of deflection in service
- lifeboat davit wire falls older than 24 months were being replaced with follow up replacements within 36 months
- re-emphasis of Holland America Line's fall protection programme for shipboard personnel
- re-assessment of Holland America Line's work-at-height risks and the putting in place of a programme of further training of shipboard personnel involved in working at heights
- the issuing of all sailors with appropriate work vests (buoyancy aids)
- development of wire and davit maintenance greasing plans for the various types of davits to include diagrams of the davits and hoisting wire and travelling wire layouts on the davits to ensure 100% of the wire lengths and davit greasing points are greased
- a review to ensure that all wire specifications listed in Holland America Line's database reflect the specifications provided by Navalimpianti and to ensure that no wires can be ordered from any other vendors and a system is in place to monitor wire age, and
- a swimming lesson programme has been started at Holland America Line's training school in Indonesia

7. Recommendations

General

- 7.1. The Commission may issue, or give notice of recommendations to any person or organisation that it considers the most appropriate to address the identified safety issues, depending on whether these safety issues are applicable to a single operator only or to the wider transport sector. In this case, recommendations have been issued to the Navalimpianti Tecnimpianti Group, with notice of these recommendations given to the Dutch Safety Board, the International Association of Classification Societies, the Cruise Lines International Association, and Maritime New Zealand.
- 7.2. In the interests of transport safety it is important that these recommendations are implemented without delay to help prevent similar accidents or incidents occurring in the future.

Recommendations

- 7.3. On 23 February 2011 in the interim factual report, the Commission made the following recommendations to the Vice President of the Navalimpianti Tecnimpianti Group.
- 7.4. The Commission believes it is a safety issue that the design of the SPTDL-150P lifeboat davit does not facilitate a thorough examination or effective lubrication of the standing part of the wire falls where they pass around the fixed guides before terminating. Lack of effective lubrication in this area will promote rapid corrosion and possible premature failure of the wire rope fall. Difficulty in conducting a thorough examination of the wire rope in this area could result in the risk of possible premature failure of the wire rope going undetected.
- 7.5. The Commission believes it is a further safety issue that the design of the SPTDL-150P davit allows the outer ends of the fixed arm to flex towards the adjacent moving trolley beam when the load is taken by the wire falls. There is evidence that this flexing can cause the trolley beam structure to contact the wire guides, and possibly the wire falls, which could lead to excessive wear and premature failure of the wire rope.

Recommendation 1

It is recommended that as a matter of urgency, the Navalimpianti Tecnimpianti Group alert all owners of vessels fitted with the SPTDL-150P stored-power telescopic lifeboat davits of the circumstances of this accident and issue instructions on what immediate inspections and maintenance should be carried out to prevent a failure of wire rope falls for the same or similar reasons. (009/11)

Recommendation 2

It is recommended that as a matter of urgency, the Navalimpianti Tecnimpianti Group make a technical assessment of other lifeboat davit models it has produced to identify if similar safety issues exist with those models, and if so, alert owners of those davits and issue them with instructions on what immediate inspections and maintenance should be carried out to prevent a failure of wire rope falls for the same or similar reasons. (010/11)

Recommendation 3

It is recommended that as a matter of urgency, the Navalimpianti Tecnimpianti Group review the design of the SPTDL-150P lifeboat davit system with a view to remedying the tendency in this case for the fixed davit arm to flex inwards under load and contact moving parts of the structure, which could lead to premature failure of components within the system. (011/11)

- 7.6. On 17 March 2011 the Chief Executive of Navalimpianti Tecimpianti Group replied to the safety recommendations, a summary of which is included here:

Recommendation 1

We have issued a service bulletin to all owners highlighting critical aspects for the maintenance of the wire ropes. [see Appendix 1]

Recommendation 2

We are in the process of assessing all our other davit models to identify if similar safety issues exist with those models and if so we will issue them with instructions on what is required.

Recommendation 3

Regarding the deflection of the fixed davit arm, we have proposed the addition of a strong steel connection illustrated on the enclosed drawing [see Appendix 2]. This solution has the advantage that it can be installed on board without dismantling the inner telescopic beams of the davit arm.

Before finalising this modification to the existing davits it will first need to be approved by the relevant Classification Societies.

8. Key lessons

- 8.1. A wire rope is only as good as its weakest part. Unless an inspection covers the entire length of the wire, a **thorough** inspection has not been made.
- 8.2. Wire ropes in a marine environment require frequent and thorough lubrication to prevent corrosion; otherwise other measures will need to be taken to prevent premature failure of the wire ropes.
- 8.3. When selecting a securing point for a safety harness, consideration should be given to its vulnerability in the event of other catastrophic failures.
- 8.4. A personal buoyancy device should always be worn when working outside of a ship's rail.
- 8.5. Robust job hazard analysis can prevent injuries and save lives, but only if the procedures that result are then followed by the crew.

9. Citations

Health and Safety Executive UK. (1995). *Improving compliance with safety procedures*. London: HSE Books.

Mason, S. (1997). *Human factors in safety-critical systems*. Oxford: Butterworth.

Reason, J. (1990). *Human error*. New York: Cambridge University Press.

Shappell, S. A., & Wiegmann, D. A. (2000). *The human factors analysis and classification system - HFACS*. Washington D.C.: Office of aviation medicine.

Steinman A, G. G. (2001). Cold water immersion. In G. G. Steinman A, & A. P. (Ed.), *Wilderness Medicine 4th edition*. St. Louis: C.V. Mosby.

United Kingdom Hydrographic Office. (2007). *Admiralty Sailing Directions, New Zealand Pilot, NP51*. Taunton, United Kingdom: United Kingdom Hydrographic Office.

Appendix 1 Navalimpianti Technimpianti Service Bulletin

NAVALIMPIANTI TECNIMPIANTI GROUP	SERVICE BULLETIN	No. 001/11 Date : 14 January 2011 Page 1/2
---	-------------------------	---

Product	STORED POWER TELESCOPIC DAVITS Types : SPDT L150P - SPDT T150P - SPDT L150P
Purpose	Maintaining the efficiency and reliability of the hoisting wire ropes
Summary	Inspection and maintenance to the fixed connection ends

Description

In several types of telescopic davits the fixed end of the wire rope is deviated before to reach the spelter socket of the fixed connection by means of a fixed steel sheave guide. This steel sheave guide is arranged in front of the fixed frame of the davit arm (see the detail in the picture).

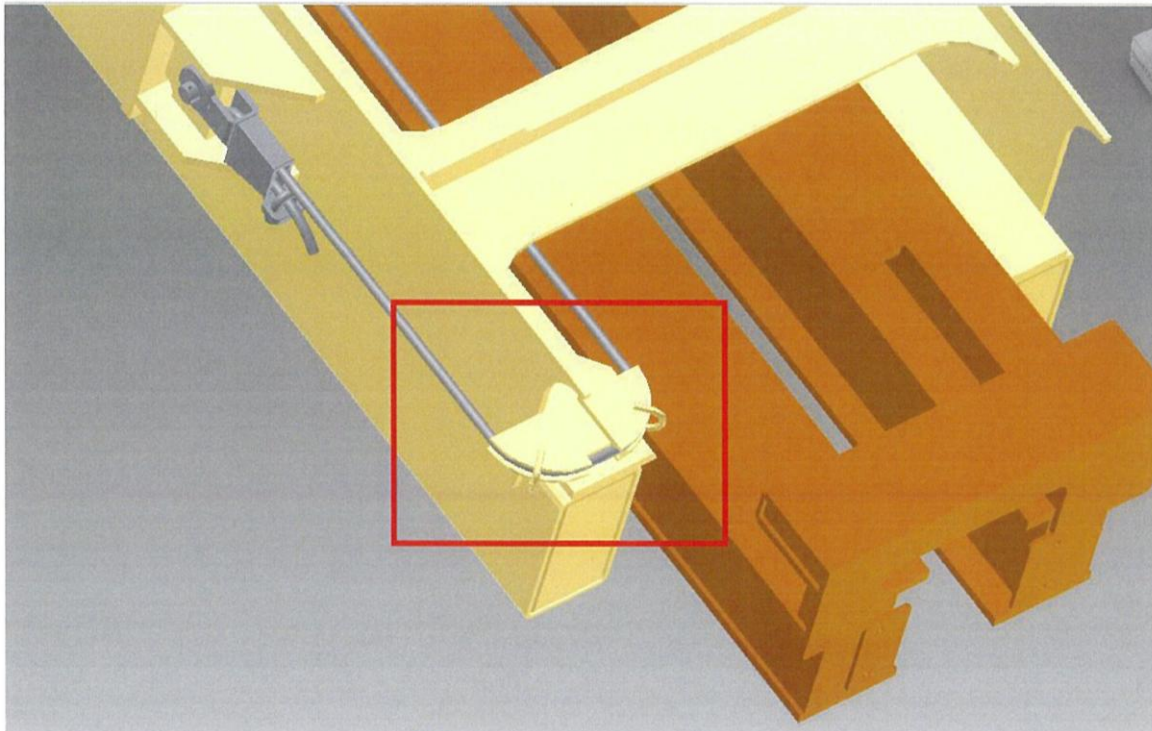

It is mandatory to inspect periodically the efficiency of the whole length of the wire rope with special regard to the areas passing through the sheaves including the rope's length along this guide.

It is also mandatory to renew the falls when necessary in way of deterioration or at intervals of not more than 5 years, whichever comes earlier.

Routine maintenance includes visual inspection and greasing of the wire ropes.

Greasing interval should be adjusted to the service conditions of each single station considering that high frequency of operation and bad environmental conditions may recommend to reduce this interval that should not exceed, in any case, 6 months. Visual inspection is recommended every month and as general checking before each operation.

Attention has to be paid to identify wire corrosion and broken wires in the standing rope on the fixed sheave guide and at both sides of this one.

From the service platform or the embarkation deck it is possible to observe only the last part of this guide, since the most part is hidden by the arm. Thus periodical inspection has to be made from the boat, moving the telescopic arm to check this part of wire rope on its entire length. During this operation pay attention to follow the instructions given in the safety warnings.

If the standing rope is corroded or the broken wires exceed 2 breaks at fixed end and 3 breaks on a length of 10 diameters, the rope end is to be cut (for the maximum length of one drum coil, corresponding to about 2 m, for lifeboat and tender davit). This permits to renew the fixed connection.

Important cautions.

- The end cutting operation can be done only one time otherwise the wire has to be changed and reinstalled according the procedure set in the operating manual. For this purpose please refers also to LSA guidance note 3 – Fall wire inspection and maintenance.
- The above inspections are to be carried out on all fixed connections. Records of inspections, maintenance and end cutting shall be updated indicating the date, the davit number, the fall (fore or aft) and the cut length of fall, if done.
- It is also recommended to check the wire rope fixed connection, as above described, during any other maintenance operation to the falls that are carried out extending the davit arms (i.e. during greasing operations).
- Do not cover with grease the rusted parts of the ropes without having alerted the safety officer for a more accurate check.
- When checking the falls integrity, verify also the status of the steel structures for corrosions, wears, deformations, etc. If any of these is found, report this one to our Service Dept, possibly together to digital pictures relevant to the interested areas.

Safety warnings. For all these inspections and all maintenance operations to the fixed connection, fasten the boats with the maintenance.

The reliability of the wire ropes is improved slacking the ropes after the boat stowing. People are to be secured by safety belt hocked to a safety line or to the lifespan (if not corroded) and they are to wear floating jacket. Remember that the lifespan cannot be tightened.

It is recommended, when carrying out the above mentioned activities, to comply with applicable Health, Safety and Environment instructions and procedures.

For any further information please contact our service dept.

Appendix 2 Navalimpianti Technimpianti

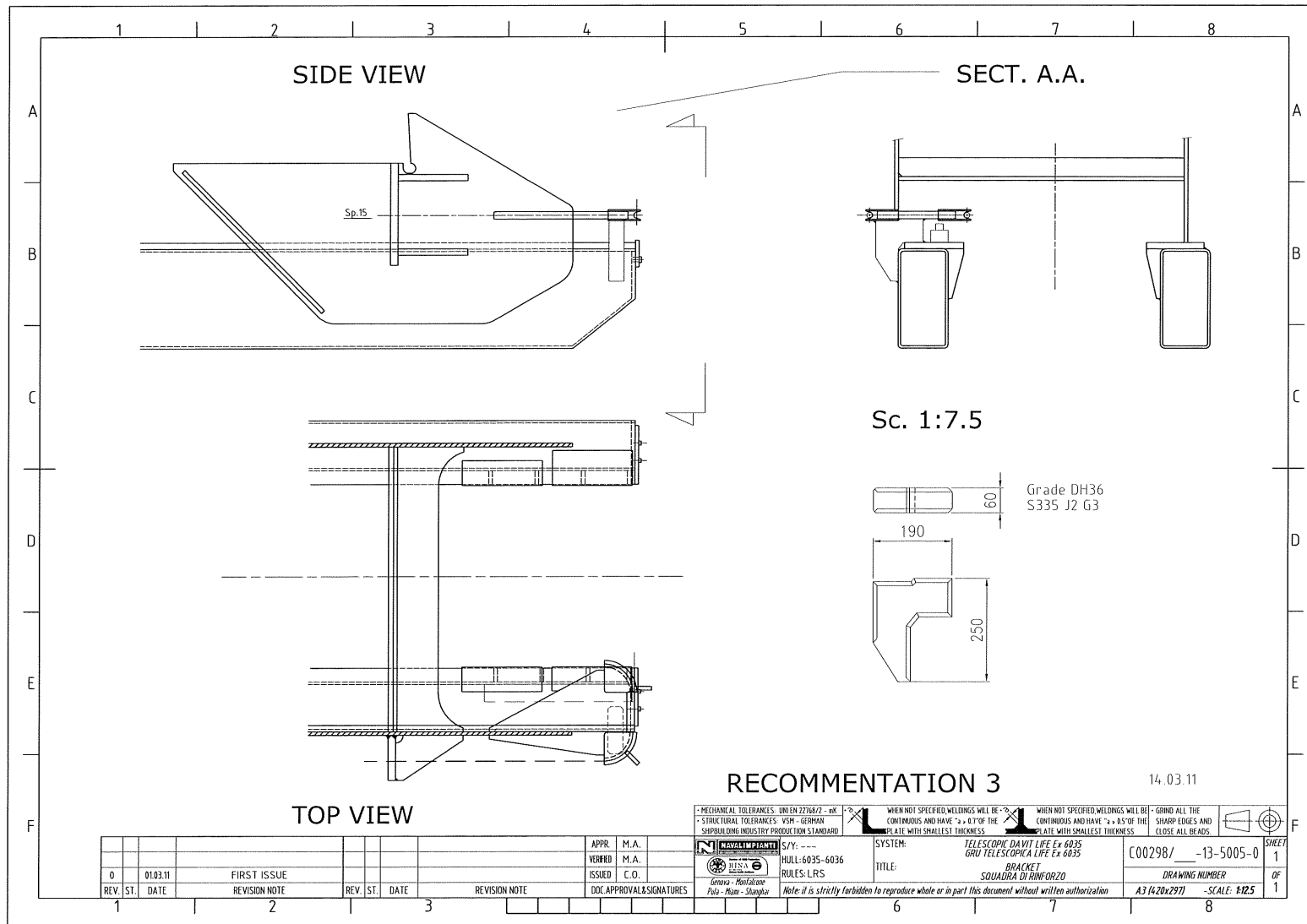

Job Hazard Analysis

m.s. Volendam

Job no: 0001 Job: Working Aloft and Outboard

Department : Deck Department
Responsibility : Chief Officer
Sub responsibility : Bosun

Job description : Any work carried out that is more than 2 meters above deck or over water. Working outside the ships railings/enclosures, on top of lifeboats, in masts/funnels.

Hazard description : Slipping, sliding, tripping or losing ones balance causing the individual to potentially fall down more than 2 meters.
 Dropping tools etc. down to the area below presenting a potential hazard to persons in this area.

PPE required : Full Body Harness with Shock Absorbing Lanyard of max 6 Ft
 Safety Shoes
 Safety Helmet
 Work Gloves
 Safety Tape
 Work Vest

LSA required : When working over the side, a lifebuoy with sufficient length of buoyant line attached should be available for immediate use.

Usage of PPE : Don the harness fully, close all fastenings and make sure the harness is not loose. Attach the shock absorbing lanyard to a strong point (not the ladder etc. on which one is working).
 For jobs where falling objects could be an issue wear a safety helmet.
 For jobs where grabbing sharp or hot handholds could be an issue wear work gloves (e.g. hot pipes in the Engine Room)
 Seal off the area beneath the working area using danger tape.

Checks to be made No objects above the working area which could fall down
 Surface to walk/stay on is clear of objects, clean and not slippery
 2nd person on standby to assist in case of an accident and to hand tools etc.
 Strong point to attach lanyard
 Strong and safe hand/foot-holds
 Tools should have lanyards to prevent them being dropped.
 Ladders, stages or bosun's chairs are properly attached on deck.
 Lock out/tag out procedure in use for whistle/radar/steam exhaust if work is to be done on the mast or funnel.

Forms to be filed : Working Aloft Permit

Applicable MR : MR 600
Code Of Safe : Chapter 15.1 – 15.5
Working Practices

Job Hazard Analysis

m.s. Volendam

Job no: 0009 Job: Wire Greasing

Department : Deck Department
Responsibility : Chief Officer
Sub responsibility : Bosun/2nd Officer Lifesaving

Job description : **Greasing lowering and traveling wires of lifeboat davits and life raft cranes.
Greasing wires of lifting devices in general.**

Hazard description : Receiving crushing injuries due to getting hand caught in between wires and sheaves/blocks/drums.
Injuring hands due to possible flesh hooks of the wires.

PPE required : Working gloves
Safety shoes
Safety glasses or indirectly vented goggles

Usage of PPE : Wear safety shoes to prevent crushing injury of the foot when accidentally dropping a wire or slipping due to grease spills.
Wear working gloves and utilize rags to protect the hands from the possibility of flesh hooks on the wires (report finding any flesh hooks as it might be a reason to discard the wire).
Wear safety glasses or in directly vented goggles to prevent getting grease or flying debris in the eyes.
When working aloft adhere to the appropriate JHA (JHA-0001) and complete a Working Aloft Permit.

Checks to be made : Working area clear of obstructions hindering greasing operations.
Wire clear to run freely.
Area below the working area roped off to unauthorized personnel.
Wire ropes should be regularly inspected and treated with suitable lubricants. These should be thoroughly applied so as to prevent internal corrosion as well as corrosion to the outside. Wires should never be allowed to dry out.
Equipment isolated to prevent use of davit/crane or equipment that wire is attached to.

Forms to be filed : None

Applicable MR : MR-600
Code of Safe : Chapter 21.2.28
Working Practices

06/23/2009 8:15:00 AM > JHA-0009-Wire Greasing.doc

Working Aloft Permit

Work Location: Deck 4 at lifeboat stations SB	Work Description: Greasing traveling wires SB tenders and lifeboats
Date/Time: January 8 2011, 08:00.	
Valid for 10 hours from time of issue.	

Section 1 to be completed by the person going aloft or if more than one person is going aloft, the person in charge.

Have you been briefed on the job requirements?	Yes <input checked="" type="checkbox"/>
Are you competent to carry out the job?	Yes <input checked="" type="checkbox"/>
Are there enough persons for the job?	Yes <input checked="" type="checkbox"/>
Are you wearing a full body harness?	Yes <input checked="" type="checkbox"/>
Has all equipment been checked?	Yes <input checked="" type="checkbox"/>
Are there adequate securing points?	Yes <input checked="" type="checkbox"/>

To be signed by the worker

I have checked the items in Section 1 and am satisfied that they are correct.

[Signature]

Section 2 Isolation of equipment to be completed by the person who completed Section 1.

Do any of the following require isolation?	Yes <input type="checkbox"/>	No <input checked="" type="checkbox"/>
Whistle	Yes <input type="checkbox"/>	No <input type="checkbox"/>
Scanners / Radar Units	Yes <input type="checkbox"/>	No <input type="checkbox"/>
Aerials	Yes <input type="checkbox"/>	No <input type="checkbox"/>
Lights	Yes <input type="checkbox"/>	No <input type="checkbox"/>
Boiler Soot blowers	Yes <input type="checkbox"/>	No <input type="checkbox"/>
Steam Vents	Yes <input type="checkbox"/>	No <input type="checkbox"/>
Other (specify)	Yes <input type="checkbox"/>	No <input type="checkbox"/>

If the answer to any of the above is yes, then the supervising officer must indicate that the equipment has been isolated

I am satisfied that the equipment marked yes has been isolated and notices have been posted on it.

[Signature]

Special Conditions:

Authorization: Signed by a supervising officer who is not going aloft for the permitted event.

I am satisfied that the work is necessary, the above checks have been carried out and that it is safe for the work to commence. I have considered the safety aspects of current and expected weather and sea conditions.

[Signature]

Note: Working Aloft permits are not required for work using portable ladders.

Toolbox Discussion Form

Date:

1/7/2011

Job Description:		Continue greasing PS lifeboats traveling wires and touch up hoisting wires. Rope between blocks for safety harness.											
Potential Hazard:		Rope of deck falling in water, grease dropping in water.											
Chemical and physical hazards, refer to the JHA (Job Hazard Analysis)													
Permit	Yes	<input checked="" type="checkbox"/>	No	<input type="checkbox"/>	JHA available	Yes	<input checked="" type="checkbox"/>	No	<input type="checkbox"/>				
PPE to be used													
Dust Mask	Respirator	Eye Protection	Ear Protection	Gloves	Hard Hat	Boots	Apron	Harness	Face Shield	Heavy Lift Precautions	Signs or Barriers	Inflatable Lifejacket	Lock out Tag out
<input type="checkbox"/>	<input type="checkbox"/>	<input type="checkbox"/>	<input type="checkbox"/>	<input checked="" type="checkbox"/>	<input type="checkbox"/>	<input type="checkbox"/>	<input type="checkbox"/>	<input type="checkbox"/>	<input type="checkbox"/>	<input checked="" type="checkbox"/>	<input checked="" type="checkbox"/>	<input type="checkbox"/>	<input type="checkbox"/>
Employee:	Signature :												
Employee:	Signature :												
Employee:	Signature :												
Employee:	Signature :												
Employee:	Signature :												
Employee:	Signature :												
Employee:	Signature :												
Employee:	Signature :												
Employee:	Signature :												
Employee:	Signature :												

Supervisor:

PPE Usage verified
Supervisor:



**Recent Marine Occurrence Reports published by
the Transport Accident Investigation Commission
(most recent at top of list)**

- | | |
|----------------------|--|
| 11-201, | Passenger vessel Volendam, lifeboat fatality, Port of Lyttelton, New Zealand, 8 January 2011 |
| 10-203 | Marsol Pride, uncontrolled release of fire-extinguishing gas into engine room, Tui oil and gas field, 27 May 2010 |
| 09-204
and 09-207 | Coastguard rescue vessel Dive! Tutukaka Rescue collision with rocks, Taiharuru River entrance Northland, 4 March 2009; Coastguard rescue vessel Trusts Rescue, heavy weather encounter, Manukau Bar, 31 May 2009 |
| 10-201 | Bulk carrier TPC Wellington, double fatality resulting from enclosed space entry, Port Marsden, Northland, 3 May 2010 |
| 09-201 | Collision: private jet-boat/private watercraft, Kawarau River, Queenstown, 5 January 2009 |
| 08-209 | Loss of the rigid inflatable boat Mugwop, off the entrance to Lyttelton Harbour, 28 October 2008 |
| 11-201 | Interim Factual report - Passenger vessel Volendam, lifeboat fatality, port of Lyttelton, New Zealand, 8 January 2011 |
| 08-205 | Fishing vessel, <i>San Cuvier</i> , dragged anchor and grounded, Tarakeha Point, Bay of Plenty, 27 July 2008 |
| 08-206 | Passenger ferry Monte Stello, collisions with wharfs, Picton and Wellington, 8 and 9 August 2008 |
| 09-205 | Stern trawler Pantas No.1, fatality while working cargo, No.5 berth, Island Harbour, Bluff, 22 April 2009 |
| 09-203 | Jet boat, DRJS-11 grounding and subsequent rollover Dart River, near Glenorchy, 20 February 2009 |
| 08-203 | Passenger Ferry Monte Stello, Loss of Power, Tory Channel, 2 May 2008 |
| 08-207 | Commercial Jet Boat Kawarau Jet No. 6, Roll-Over, confluence of the Kawarau and Shotover Rivers, 25 September 2008 |
| 08-204 | 6-metre workboat Shikari, collision with moored vessel, Waikawa Bay, Queen Charlotte Sound, 20 June 2008 |

Price \$38.00

ISSN 1173-5597 (Print)
ISSN 1179-9072 (Online)